



The Safe Way

A GENERAL GUIDE TO THE SAFE AND EFFICIENT INSTALLATION
AND OPERATION OF WOOD HEATING APPLIANCES

from Farm Bureau Insurance

Take Extra Care

Years ago, when wood heating was more the norm than the exception, people were accustomed to working with it. The extra time and safety precautions involved were just a natural part of the home heating process. Even then, however, fires were all too common.

People today are accustomed to the ease and convenience of modern heating appliances. A professional heating contractor installs the furnace, maintains it, and repairs it. More often than not, the homeowner's only connection with the device is the thermostat on the wall.

If you are planning to install a wood heating stove – or update your present system – we urge you to spend

some time with this brochure. It is not meant to scare you or discourage you from using wood as an economical heating alternative. We just want you to know that heating with wood requires extra care on your part – and we want to help you make it safe for your home.

That doesn't mean that if you follow our suggestions you'll never have a problem with wood heat. But if you heed the guidelines here, conform with building code requirements, and rely on the research you've done on your own as well as on information from experts, you'll feel a lot more secure.

Which stove is best?

Many models are available. It's up to you to determine which will best fit your particular needs. The three most common materials used in the manufacture of stoves are sheet metal, plate steel, and cast iron. Wood stoves that do not have a label indicating that they have been tested and approved by Underwriters Laboratory are usually not acceptable for insurance purposes.

Sheet Metal

- Least-expensive alternative.
- Commonly installed in shops.
- Has a life expectancy of about five years, depending on metal gauge.
- Should be inspected regularly for thin spots.

Plate Steel

- Usually 1/8 inch to 3/4 inch thick.
- Has longer life expectancy than most sheet metal types.
- Retains heat longer than most sheet metal types.
- Requires special attention to good draft control.

Cast Iron

- Often lasts a lifetime.
- Holds up well under extreme heat.
- Heats up slowly, retains and radiates heat for a long time.
- Will crack if dropped.
- Should be inspected for damage if a used model.

Find a good place

Your stove should be placed in a central area for greatest heating efficiency. And it should be in a place where it can be supervised during operation.

Be prepared

No matter how carefully you install your stove, or what kinds of precautions you take, there is always the possibility that something could go wrong. That's why you should have:

- A U.L.-approved fire extinguisher placed in the vicinity of (but not right next to) your stove.
- A smoke or smoke/fire detector placed near your sleeping quarters, but far enough away from the stove to keep the detector from sounding off in the presence of normal heat radiation or intermittent smoke that may be given off during start-up or refueling.
- Portable, folding escape ladders placed under beds or window sills in bedrooms for emergency use.
- An emergency exit plan for your home.

Remember: Over 80% of all fire-related deaths occur in residential properties, and smoke inhalation causes more deaths in home fires than burns do.

The chimney

Your best choice is a new masonry chimney with an approved clay liner – or else the U.L.-approved prefabricated type. Do not use an emergency stovepipe chimney. When you purchase a chimney, be sure the merchant or contractor is knowledgeable, willing to give detailed information, and able to back the product.

Prefabricated chimney

- Constructed more easily than other types, but must be installed according to manufacturer's instructions and clearances.
- Must be insulated, must be approved by U.L. and must meet standards of U.S. test 103 H.T. or comparable test.
- Must be rated as all-fuel chimney.
- Has stainless steel outer casing, one inch of insulation, and stainless steel inner lining.
- Locks together with no special tools or screws.
- Heats up rapidly inside, and inside stays warm to prevent creosote buildup.
- Should be inspected annually and after any chimney fire for thin spots.
- Can be used as a liner for an existing masonry chimney that has been judged unsafe.

Masonry chimney

- Costs less for materials, but labor is costly.
- Lessens danger of a burn-through fire inside the chimney.
- Should be large enough to provide adequate draft. Cross-sectional area of the chimney flue should be at least 25 percent greater than that of the connecting stovepipe.
- Must always have a tile liner.
- Can be constructed of brick, cement block, or stone.
- Must be constructed with proper clearances from walls, floors, roofs, ceilings, and other burnable material.

Existing masonry chimney

- Should be inspected thoroughly and cleaned before use.
- Requires the services of a mason for needed repairs and safety measures.
- If not already lined, should be lined with a prefabricated chimney or clay flue tiles.

Chimneys that service wood heating stoves should be professionally inspected annually to prevent chimney fires. And every kind of chimney should be inspected after a chimney fire by a qualified chimney sweep.

Chimney installation

A chimney has two basic purposes: to create draft and to evacuate the gases of combustion. Both are very important to the safe operation of your stove, so you must follow certain guidelines.

- Your chimney, whether fabricated or masonry, should extend at least three feet above a flat roof or two feet above any ridge within ten feet. There should also be at least 16 feet between the stove outlet and the top of the chimney.
- *Never vent more than one heating appliance into one flue.* Otherwise, incomplete combustion of gas or oil might result in explosion or fire if one or the other is ignited by sparks from the wood stove. Fumes – including carbon monoxide – and sparks could also enter the room through either unit.

The stovepipe connector

The pipe connecting your stove to your chimney is often little more than three feet long, but it plays a vital role in the safe operation of your wood stove. Remember:

- Keep the connector as short as possible.
- The steel should be at least 24 gauge.
- Each joint (if you're using more than one section) should be fastened securely with at least three sheet metal screws.
- If the pipe is more than six feet long, it requires other mechanical support of weight.
- If a masonry chimney is used, the stovepipe should extend to the inner surface of the masonry wall, but not into the flue space itself.
- Clearance between the connector and any combustible materials should be at least 18 inches.
- If more than one section is used, the upper pipe should be fitted over the lower pipe to prevent air leaks.
- Try to avoid 90-degree angles in the stovepipe construction; instead, use a few gentle 45-degree turns.
- Do not reduce the size of the stovepipe from the outlet to the chimney. Otherwise you might get backup smoke.

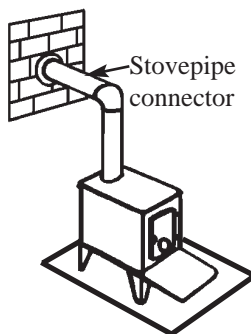

- If the stove is not equipped with a damper, one should be built into the stovepipe connector to control draft and loss of volatile gases.
- If a stovepipe connector must pass through a wall, there should be no combustible materials within 18 inches of the pipe. The clearance area can be filled with brick or

masonry, which can then be covered with drywall or metal.

- You may reduce the required clearance from 18 inches to 2 inches by installing a section of double-wall insulated pipe through the wall.

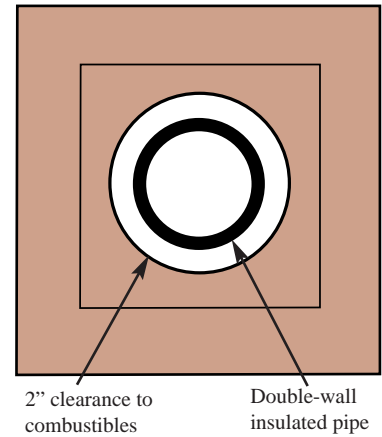
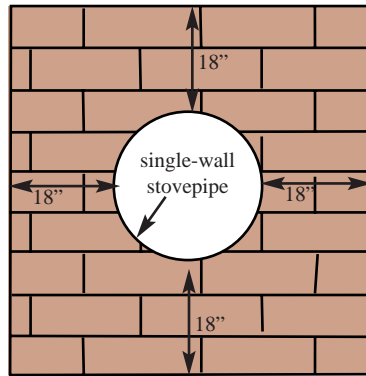

Clearances

(always follow stove manufacturer's recommendations)

Floor protection

- Metal combination board, slate, brick, or marble cut to extend 18 inches beyond the stove on all four sides should be installed.

Walls and Floors

- A radiating stove should be at least 36 inches from any unprotected surfaces, including walls, floors, and furniture.

- Clearances for circulating stoves should follow manufacturers' recommendations.

- The stove interior should be lined with firebrick.
- A two-inch layer of sand or ash should be maintained in the bottom of the firebox.

- The stove legs should be at least six inches long. If they aren't the stove should sit on bricks to maintain the air space between the protected floor and the stove.

Wall protection

- Metal-covered combination board, brick, stone, or other masonry material should be installed.
- One-inch fireproof spacers should be installed between the wall and the protective surface so that air can circulate freely behind.

Stove Clearances

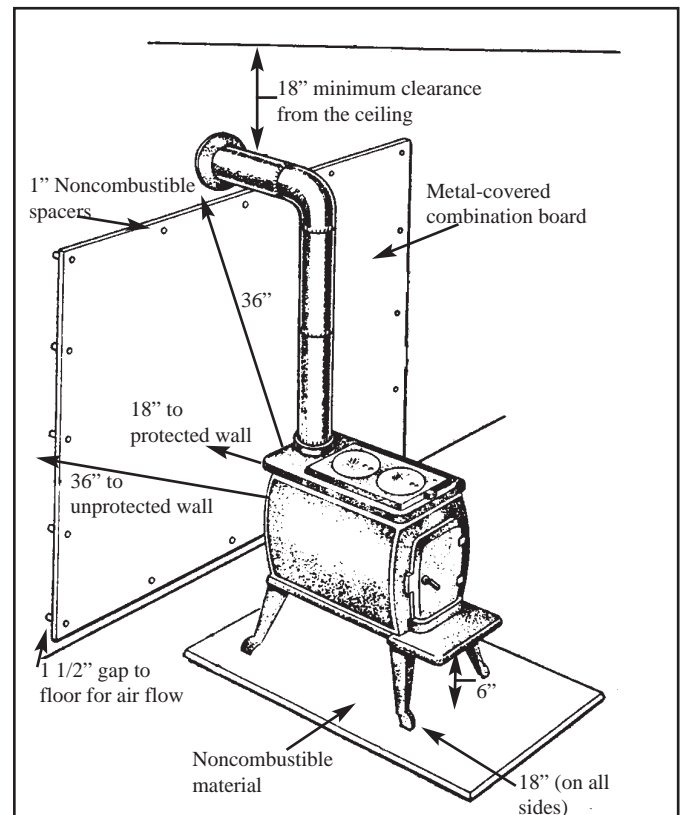

Firing and stoking the stove

- When you start a fire for the first time, place a small amount of paper in front of your pile of kindling and place the larger logs on top of the kindling.
- Never use gasoline, kerosene, charcoal starter, or any other flammable liquid to start a fire. Flash fire or

explosion could result, and fumes from these liquids are extremely dangerous.

- Realize that it may take several tries to establish a fire in your stove, depending on your methods and materials. Take the time you need to start a proper fire with a proper fuel.

Firing and Stoking, cont.

- When you start your fire, open the draft and damper wide. This will make the fire catch quickly and will allow less backup smoke into the room. Soon after the fire catches, however, the controls should be adjusted down again.
- When you stoke the fire, open the draft and damper for a minute or two before you open the stove. You'll keep a

Problems

Creosote

Creosote is generally a sticky, tar-like substance that accumulates in your chimney as a result of incomplete combustion. Over time, it can crystalize on the surfaces of your chimney and pipes.

When controlled properly, creosote is a minor irritation that you can easily clean out. But when it accumulates, creosote becomes dangerous – and one spark can turn your chimney into an inferno.

You can't avoid creosote, but you can control it by following a few guidelines and inspecting and cleaning your chimney regularly.

- When installing your stovepipe connector, use the tap test. Tap the pipe with your fingernail and remember the sound it makes. Repeat the procedure every week during your first season of operation and monthly thereafter. If the *clink* sound turns into a *thud*, you'll know it's time for a further inspection.
- It's important to use dry, well-seasoned hardwoods for burning and to use short, hot fires during milder weather rather than long, smoldering ones.
- It's a good idea to stoke up a fire once a day to make it burn hotter for a short period. This will warm the chimney and help reduce creosote buildup.
- Creosote tends to build up more quickly with newer, airtight stoves because less air escapes into the chimney. Regular inspections and frequent cleaning are important.
- Try to avoid sags or sharp turns in the stovepipe connector. They tend to accumulate more creosote.
- Insulate any pipe that is exposed to cold air or drafts.

lot of smoke from entering the room. Again, remember to adjust them down soon after.

- If your home is tightly insulated, you might want to crack a window to ensure proper draft – or install an outside air supply for your wood stove – for safe and efficient operation.

Remember: One spark can set a creosote-filled chimney on fire. Never burn paper or other household waste in your wood stove. Keep your chimney as clean and free of obstruction as possible.

Backup smoke

This is an irritating and potentially hazardous problem. When the stove is being loaded, a little smoke is natural and can usually be avoided if you open the damper and draft controls briefly before opening the stove. But a lot of smoke means that something is wrong – such as:

- You have more than one heating unit operating on one flue.
- Your house is located in a forest clearing and may require a taller chimney cap to avoid down drafts from the treetops.
- A hill or large building is nearby.
- The chimney is blocked by birds' nests, creosote, fallen masonry, or some other obstruction.
- The chimney is not tall enough.
- The stove outlet is less than 16 feet from the chimney top.

Backup smoke can let dangerous gases, including carbon monoxide, into your home. If you can't readily solve the problem, contact an expert immediately.

Chimney fire

- Call the fire department at once.
- Close off the oxygen supply (if your stove is an airtight model).
- Use a U.L.-approved fire extinguisher.

We strongly suggest that, in addition to reading this brochure, you get a permit before installing your wood stove, contact other experts, and follow the building codes in your area. These guidelines are offered for your protection – not as a total solution to any wood heating problems you may face, but as a way to help you reduce the potential dangers of heating with wood.

Farm Bureau Insurance includes three companies: Farm Bureau Mutual Insurance Company of Michigan, Farm Bureau General Insurance Company of Michigan, and Farm Bureau Life Insurance Company of Michigan. These Lansing-based companies provide property/casualty and life insurance coverages to more than 350,000 policyholders throughout Michigan. A field force of more than 425 professional agents and claim representatives is dedicated to providing dependable insurance service to policyholders in rural, urban, and suburban areas.

Farm Bureau Mutual is the leading farm insurer in the state, providing protection for more Michigan farm property than any other insurer.

